

**Truck**  
Fresco Plus Air-Conditioning

## FRESCO PLUS - for Fuel Economy, Driver Fatigue Management and Comfort in Mobility

Economics and Safety are major considerations for Fleet Operators. Most companies pursue aggressive idle-reduction strategies, often as part of a comprehensive safety and cost reduction management program. Workplace enhancement issues and idle-reduction go hand in hand and the Fresco Plus offers intelligent solutions to conscientious Fleet Managers and Owner Drivers alike.

With a top cooling capacity of 3245 BTU/h, current consumption of 7.5A to 14.5A (min) and unit depth specifications of 185mm, the back wall mounted Fresco Plus represents a smart, affordable solution.

In the trade-off matrix between

- noise nuisance of APU's
- the cost of high BTU air-con units
- The need for engine protection
- driver fatigue management ... and the desired good cooling effect

Fresco Plus is well placed.



**Fresco Plus installation components:**

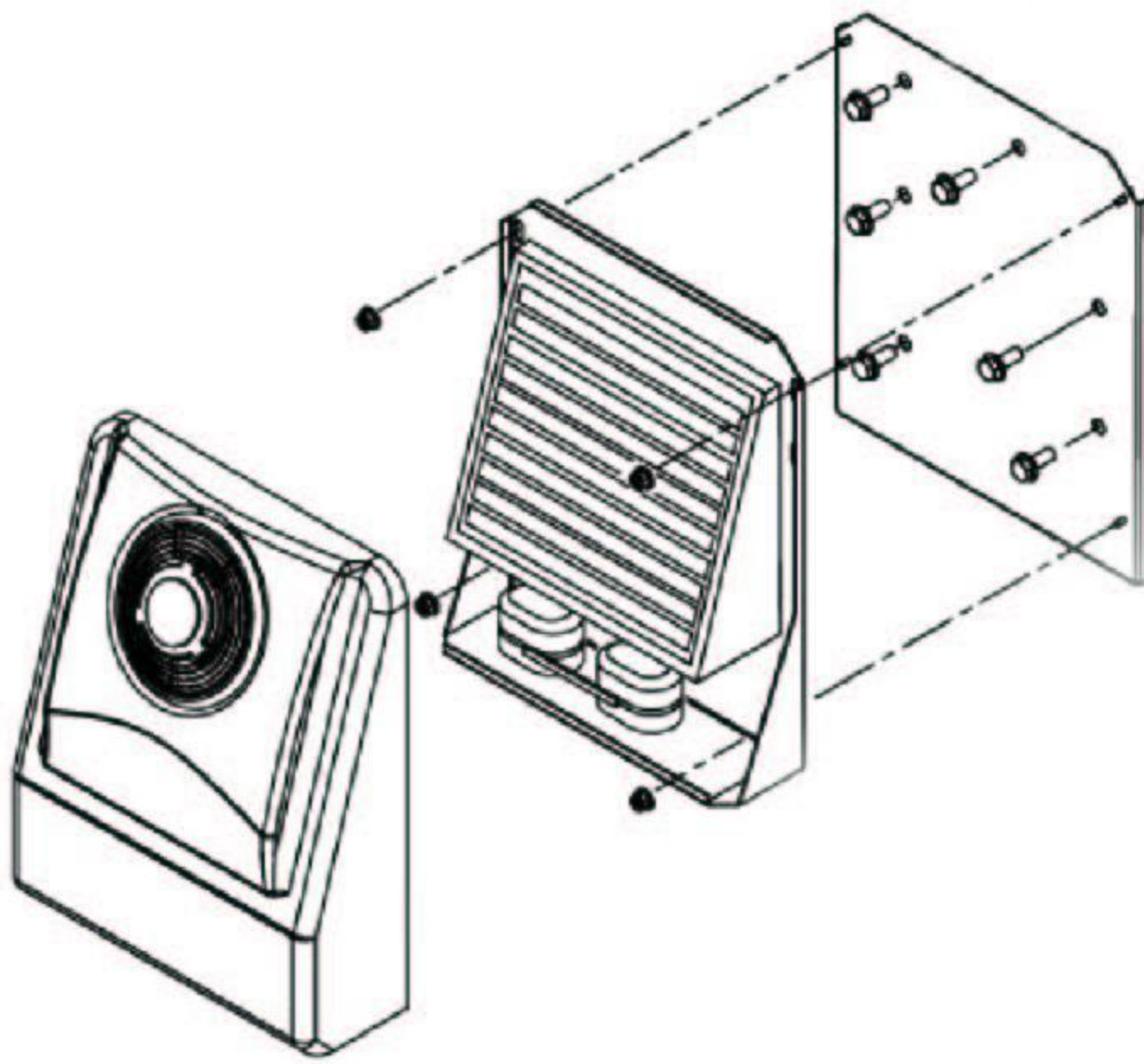

Condenser with cover mounted on backwall of the truck

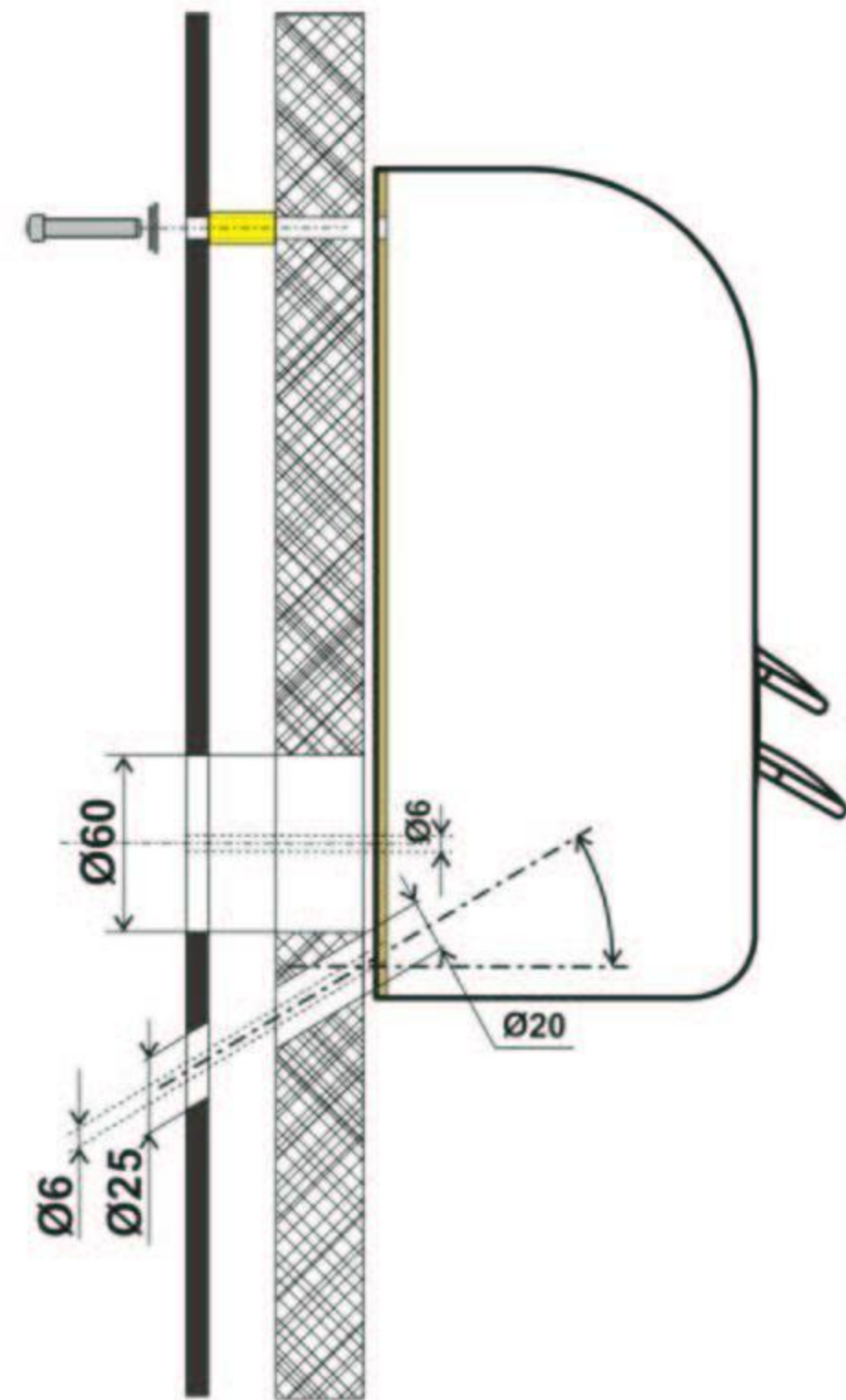

Evaporator mounting criteria

**More Unique Fresco Plus features:**

- Limited alterations to backwall - small single cut out
- One hose connection between condenser and evaporator
- Separate ECU installed in cab

Fresco Plus can be installed into most vehicles. A one meter distance is possible between the external position of the condenser and the internal placement of the evaporator. Fresco Plus can be controlled remotely or via the control panel on the evaporator. The unit is covered by a two year Webasto world-wide warranty.

**Technical specifications:**

Cooling capacity	Voltage (in V)	Refrigerant	Ventilation fan	Power consumption (in A)	Integrated battery saver	Dimensions	Weight (in kg)
950W 3245 BTU/hr	12V & 24V	R134a	6 speed	15A-29A (12V) 7.5A-14.5A (24V)	Auto switch-off with low voltage cut-out	L534xH680xD185 (C) L626xH260xD108 (E)	28,5kg (both units together)

*Webasto - Comfort in Mobility*



Advice · Installation · Service

**RENEGADE**  
Auto Cool

Unit 2 / 30 Collinsvale St  
Rocklea  
QLD 4106  
Ph: 07 3277 2815  
Fax: 07 3277 3185

[www.renegadeautocool.com.au](http://www.renegadeautocool.com.au)

